

TANAKA

AU-888

DOUBLE STAGE & NON-HEATER / FIN TYPE REGULATOR

for CO₂ & MAG GAS WELDING

Standard Feature

- Applied for CO₂ & MAG Gases
- JIS, CGA, BS Type Inlet Connection Available
- Light Weight Aluminum Fin Type
- P1: Less 12MPa for CO₂
Less 14.7MPa for MAG
- P2: 0 - 0.2MPa
- 5 - 20 L/min Flow Gauge Type
- Safety Valve Equipped
- Using Temperature: -10 ~ 40°C

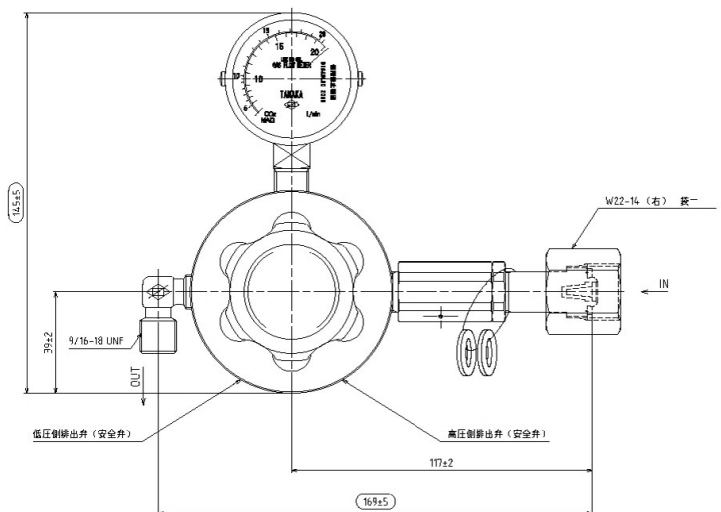
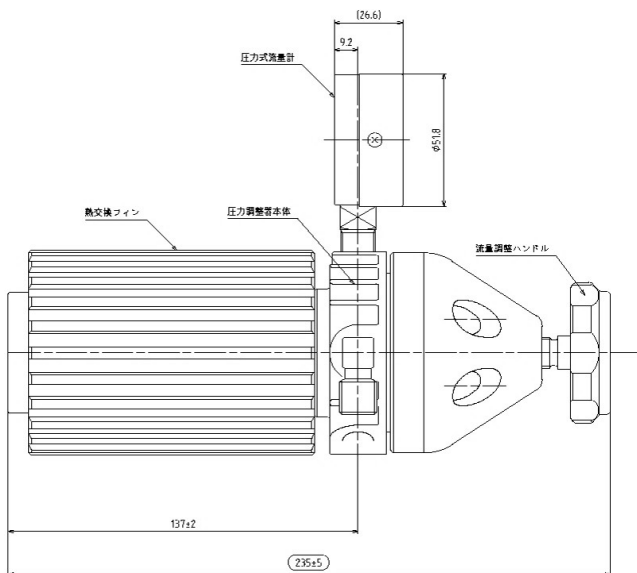
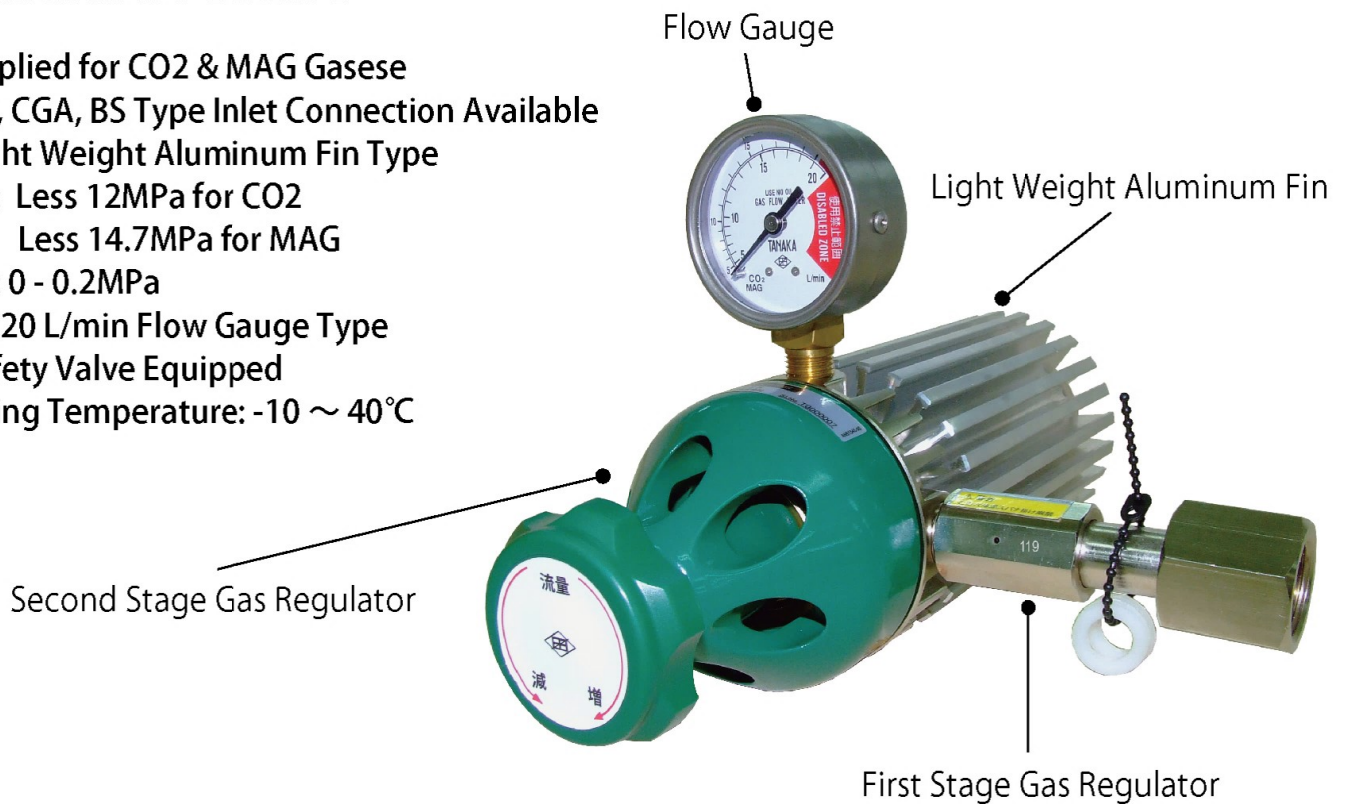

NISSAN TANAKA CORPORATION